

EIDOSWORKS Briquetting System

SUPERCOMPACT EVTM-565-LB

The EVTM-565-LB is the most advanced briquetting machine for compacting scraps.

The hopper, with its 130 liters, has been designed in its geometry to be the most capacious and efficient.

The new control logic makes the machine capable of learning and recognizing the type of chip, thus deciding the optimal operating parameters and loading times. With its 3kW and inverter control, it is capable of processing over 240 liters/hour of chip volume. A true record among its competitors.

The EVTM-565-LB optimizes energy absorption by automatically adapting its speed to the production flow.

It can be interfaced with the company information system to supply the quantities of recovered coolant and briquetted material.



The real evolution

- Use me for all metals
- I reduce the chip volume by up to 90%
- I recover the coolant
- I increase the productivity of your machines
- I reduce disposal costs
- I am completely autonomous
- I'm the most efficient
- I am ready for the challenges of 5.0

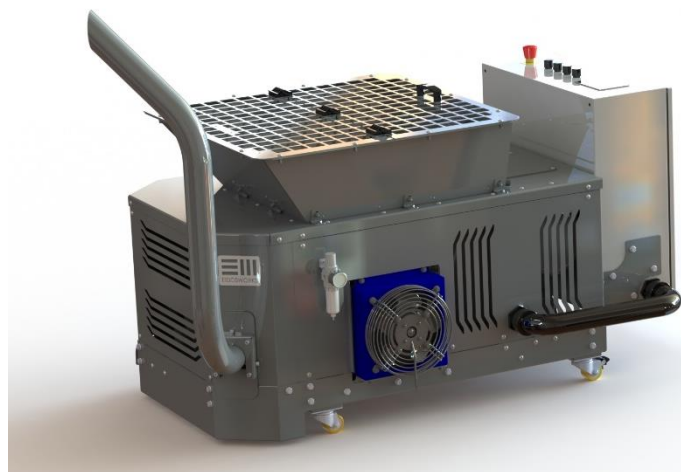

S.C. GSS EQUIPMENTS S.R.L.

Sediul:

Date înregistrare:

Cont bancar:

Adresă de coresp.:

Str. Voluntari, Nr. 30, Com. Cristian, Jud. Braşov , CP 507055

C.U.I. RO 23415104, J08/578/2008

Raiffeisen Bank, IBAN: RO 89 RZBR 0000 1640 0618

Str. Dihamului, Nr. 140, Braşov, Braşov , CP 500483

T: +40 368 460 163

F: +40 368 440 030

E: office@gssgroup.ro

www.gssgroup.ro



EIDOSWORKS Briquetting System

I'm the most compact

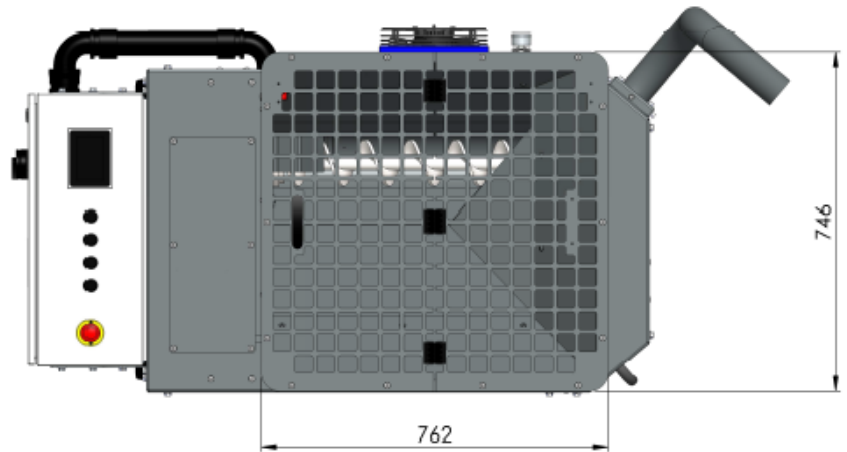
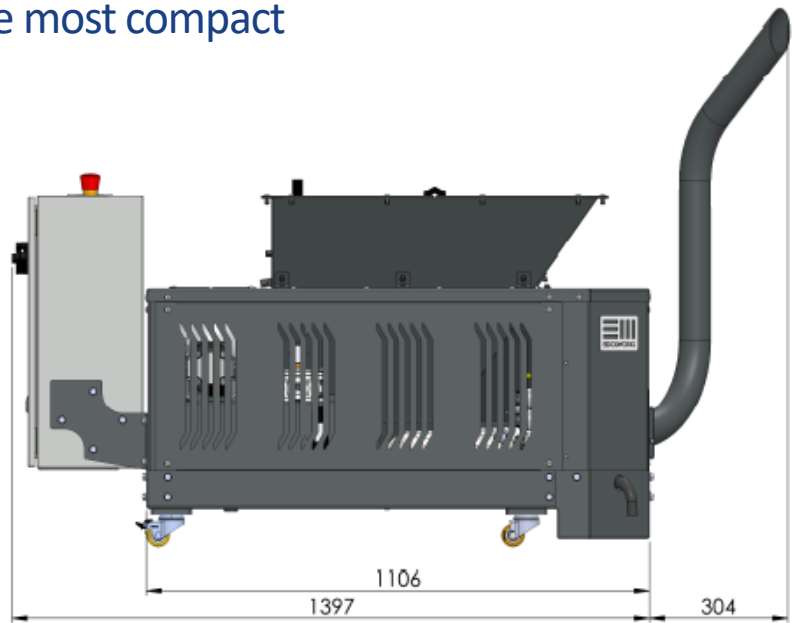
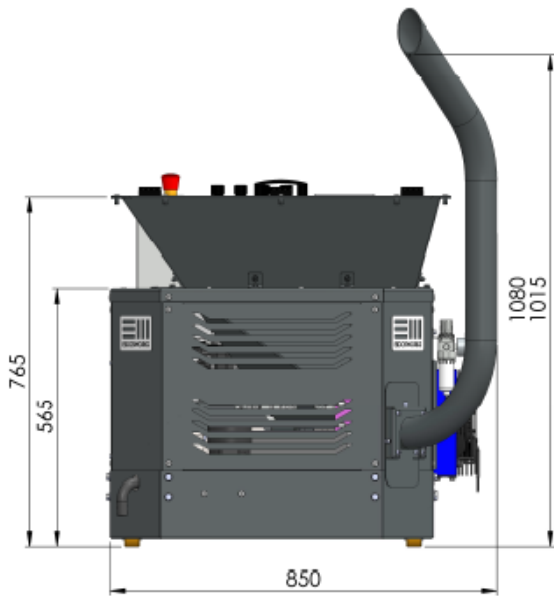

	DATA
MAIN MOTOR POWER	3 kW
STEEL PRODUCTION	60-140 kg/h
ALUMINUM PRODUCTION	30-70 kg/h
DIMENSIONS WxDxH mm	850x1106x1176
HOPPER VOLUME	130 litres
OIL TANK	30 litres
ENERGY ABSORPTION	40 Wh/kg



Eidos Works
for an efficient and environmentally
friendly process

